

*TB 9-4920-359-24

DEPARTMENT OF THE ARMY TECHNICAL BULLETIN

CALIBRATION PROCEDURE FOR ANALYZER TEST SET BENDIX, TYPE 60B63-5A

Headquarters, Department of the Army, Washington, DC
22 April 2008

Distribution Statement A: Approved for public release; distribution is unlimited.

REPORTING OF ERRORS AND RECOMMENDING IMPROVEMENTS

You can improve this manual. If you find any mistakes or if you know of a way to improve these procedures, please let us know. Mail your letter or DA Form 2028 (Recommended Changes to Publications and Blank Forms) directly to: Commander, U.S. Army Aviation and Missile Command, ATTN: AMSAM-MMC-MA-NP, Redstone Arsenal, AL 35898-5000. A reply will be furnished to you. You may also send in your comments electronically to our E-mail address: 2028@redstone.army.mil or by fax 256-842-6546/DSN 788-6546. For the World Wide Web use: <https://amcom2028.redstone.army.mil>. Instructions for sending an electronic 2028 can be found at the back of this manual.

SECTION		Paragraph	Page
	I. IDENTIFICATION AND DESCRIPTION		
	Test instrument identification	1	2
	Forms, records, and reports	2	2
	Calibration description	3	2
	II. EQUIPMENT REQUIREMENTS		
	Equipment required	4	3
	Accessories required	5	3
	III. CALIBRATION PROCESS		
	Preliminary instructions	6	4
	Equipment setup	7	4
	GEN/PMG VOLTS meter and FREQUENCY meter	8	5
	PMG volts	9	6
	CT TEST CURRENT meter	10	6
	FIELD AMPS/REG VOLTS meter	11	8
	Timer time delay	12	9
	Underfrequency circuit	13	11
	Final procedure	14	12

*This bulletin supersedes TB 9-4920-359-35, dated 1 July 2005, including all changes.

**SECTION I
IDENTIFICATION AND DESCRIPTION**

1. Test Instrument Identification. This bulletin provides instructions for the calibration of Analyzer Test Set, Bendix, Type 60B63-5A. The manufacturer's manual was used as the prime data source in compiling these instructions. The equipment being calibrated will be referred to as the TI (test instrument) throughout this bulletin.

a. Model Variations. None.

b. Time and Technique. The time required for this calibration is approximately 3 hours, using the dc and low frequency technique.

2. Forms, Records, and Reports

a. Forms, records, and reports required for calibration personnel at all levels are prescribed by TB 750-25.

b. Adjustments to be reported are designated (R) at the end of the sentence in which they appear. When adjustments are in tables, the (R) follows the designated adjustment. Report only those adjustments made and designated with (R).

3. Calibration Description. TI parameters and performance specifications which pertain to this calibration are listed in table 1.

Table 1. Calibration Description

Test instrument parameters	Performance specifications
Frequency meter	Range: 360 to 440 Hz Accuracy: +4.0 Hz
Gen/Pmg Volts meter	Range: 90 to 140 V ac Accuracy: ±2.0 V ac Range: 15 to 30 V ac Accuracy: ±0.4 V ac
Field Amps/Reg Volts meter	Range: 0 to 50 V dc Accuracy: ±2.0 V dc Range: 0 to 5.0 A dc Accuracy: ±0.2 A dc
Ct Test Current meter	Range: 0 to 3.0 mA dc Accuracy: ±0.1 mA dc
Ct Test Current meter	Range: 0 to 3.0 mA dc Accuracy: ±0.1 mA dc
Trip time circuit	
T2-3Ø, OVB	Range: 120 ms Accuracy: ±20 ms
T1-AØ, UV	Range: 3.5 s Accuracy: ±0.5 s
T2-AØ, UV	Range: 5.0 s Accuracy: ±0.5 s
T1 Underfrequency	Range: 1.0 s Accuracy: ±0.1 s
T2 Underfrequency	Range: 3.0 s Accuracy: ±0.5 s

Table 1. Calibration Description - Continued

Test instrument parameters	Performance specifications
Underfrequency circuit	
Low frequency	Range: 1095 Hz Accuracy: ± 10 Hz
High frequency	Range: 1155 Hz Accuracy: ± 10 Hz

SECTION II EQUIPMENT REQUIREMENTS

4. Equipment Required. Table 2 identifies the specific equipment to be used in this calibration procedure. This equipment is issued with Secondary Transfer Calibration Standards Sets AN/GSM-286; AN/GSM-287; or AN/GSM-705. Alternate items may be used by the calibrating activity. The items selected must be verified to perform satisfactorily prior to use and must bear evidence of current calibration. The equipment must meet or exceed the minimum use specifications listed in table 2. The accuracies listed in table 2 provide a four-to-one ratio between the standard and TI. Where the four-to-one ratio cannot be met, the actual accuracy of the equipment selected is shown in parenthesis.

5. Accessories Required. The accessories required for this calibration are common usage accessories issued as indicated in paragraph 4 above and are not listed in this calibration procedure. The following peculiar accessories are also required for this calibration: Power Supply, Sorensen Model DCS 40-30; and Power Amplifier, CPD Engineering Model 97717.

Table 2. Minimum Specifications of Equipment Required

Common name	Minimum use specifications	Manufacturer and model (part number)
CALIBRATOR	Range: 1 V ac at 396 to 1200 Hz 30 V dc Accuracy: ac $\pm 0.4\%$, dc $\pm 1.0\%$ Freq Accuracy: $\pm 0.25\%$ Range: 0 to 5 A dc Accuracy: ± 0.05 A dc	Fluke, Model 5720A (5700A) (p/o MIS-35947); w amplifier, Fluke 5725A/AR (5725A/AR)
FREQUENCY COUNTER	Range: 100 ms to 5.5 s; Accuracy: $\pm 0.02\%$	Fluke, Model PM6681/656 (PM6681/656)
MULTIMETER	Range: 10 to 30.4 V ac 8 mV to 28 V dc; Accuracy: $\pm 0.33\%$ ac $\pm 1\%$ dc Frequency: 1085 to 1165 Hz Accuracy: $\pm 0.23\%$	Hewlett-Packard, Model 3458A (3458A)
RESISTANCE STANDARD	Range: 1.1 to 3.3 k Ω Accuracy: $\pm 0.75\%$	Biddle-Gray, Model 71-631 (7910328)

SECTION III CALIBRATION PROCESS

6. Preliminary Instructions

a. The instructions outlined in paragraphs 6 and 7 are preparatory to the calibration process. Personnel should become familiar with the entire bulletin before beginning the calibration.

b. Items of equipment used in this procedure are referenced within the text by common name as listed in table 2.

c. Unless otherwise specified, verify the result of each test and, whenever the test requirement is not met, take corrective action before continuing with the calibration. Adjustments required to calibrate the TI are included in this procedure. Additional maintenance information is contained in the manufacturer's manual for this TI.

d. Unless otherwise specified, all controls and control settings refer to the TI.

7. Equipment Setup

WARNING

HIGH VOLTAGE is used or exposed during the performance of this calibration. DEATH ON CONTACT may result if personnel fail to observe safety precautions. REDUCE OUTPUT(S) to minimum after each step within the performance check where applicable.

a. Set all TI switches to down or **OFF** position.

b. Adjust all meters for mechanical zero or lowest pointer reading.

c. Connect equipment as shown in figure 1.

d. Pull **400** ⤴ **GEN-T1, T2, and T3** circuit breakers to out position.

e. Set **GEN/PMG VOLTS** switch to **T1**.

f. Set power amplifier **OUTPUT VOLTAGE RANGE** switch to 200 V and adjust **POWER AMPLIFIER GAIN** control fully ccw.

NOTE

Input voltage source (calibrator) for the power amplifier must be set to 1 Vrms as shown in green area of Regulation Range Meter of power amplifier plug-in module. Calibrator **EX SENS** must always be activated for input into power amplifier. Input frequency can be adjusted as required for desired power amplifier frequency output.

g. Set calibrator to 1 V, 400 Hz and press **EX SENS**. Set calibrator to **OPR**.

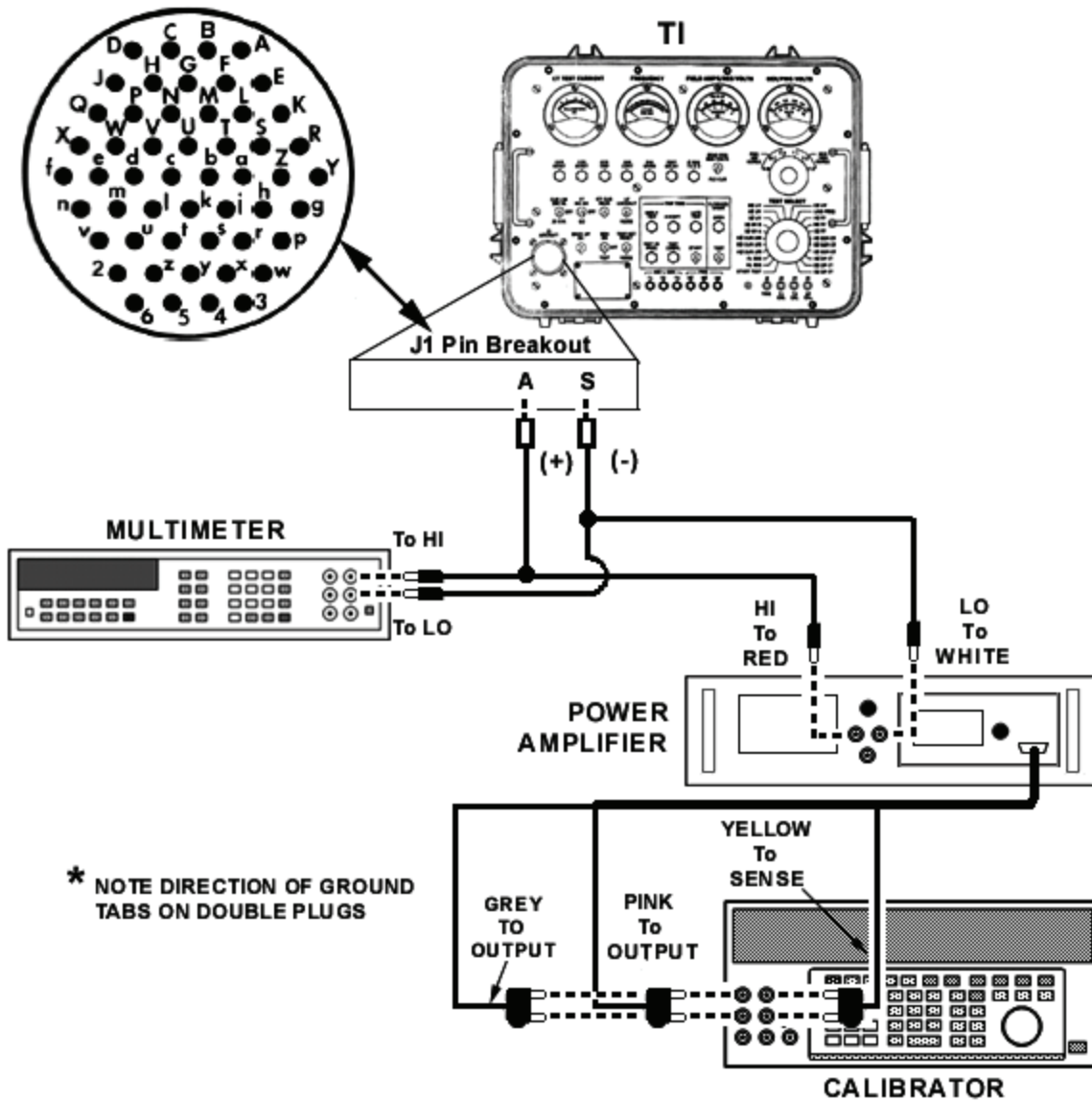

Figure 1. Power source - equipment setup.

8. GEN/PMG VOLTS Meter and FREQUENCY Meter

a. Performance Check

- (1) Push 400 \curvearrowright GEN-T1 circuit breaker to in position.

NOTE

GEN/PMG VOLTS meter will deflect downwards before increasing upwards to reflect input.

- (2) Adjust power amplifier **POWER AMPLIFIER GAIN** control for a 115 V indication on **GEN/PMG VOLTS** meter. Multimeter will indicate between 113 and 117 V ac.
- (3) Adjust calibrator frequency for a 400 Hz indication on TI **FREQUENCY** meter.
- (4) Calibrator will indicate between 396 and 404 Hz.
- (5) Adjust power amplifier **POWER AMPLIFIER GAIN** control fully ccw.
- (6) Set power amplifier **OUTPUT VOLTAGE RANGE** switch to 30 V.
- (7) Pull 400 \curvearrowright **GEN-T1** circuit breaker to out position.

b. Adjustments. No adjustments can be made.

9. PMG Volts

a. Performance Check

- (1) Remove connections at TI **J1** pins **A** and **S** and reconnect (HI) to pin **E** and (LO) to pin **D**.
- (2) Pull **PMG AØ**, **BØ**, and **CØ** circuit breakers to out positions and set **GEN/PMG VOLTS** switch to **A-B**.
- (3) Push **PMG AØ** and **BØ** circuit breakers to in positions.
- (4) Set calibrator input frequency to 1200 Hz and adjust **POWER AMPLIFIER GAIN** control for a 21 V indication on **GEN/PMG VOLTS** meter. Multimeter will indicate between 20.6 and 21.4 V.
- (5) Repeat technique of (4) above at **GEN/PMG VOLTS** meter indications listed in table 3. Multimeter will indicate within limits specified.
- (6) Adjust **POWER AMPLIFIER GAIN** control fully ccw and set calibrator to **STBY**.
- (7) Pull **PMG AØ** and **BØ** circuit breakers to out positions.

Table 3. PMG Volts

Test instrument GEN/PMG VOLTS meter indications	Multimeter indications (V ac)	
	Min	Max
18	17.6	18.4
15	14.6	15.4

b. Adjustments. No adjustments can be made.

10. CT TEST CURRENT Meter

a. Performance Check

- (1) Connect equipment as shown in figure 2.
- (2) Position TI controls as listed in (a) through (d) below:

- (a) **TEST SELECT** switch to **AØGEN CT**.
- (b) **CT CUR READ** switch to up.
- (c) **GEN/PMG VOLTS RANGE** switch to **T1**.
- (d) **400 ~ GEN T1** to in position.

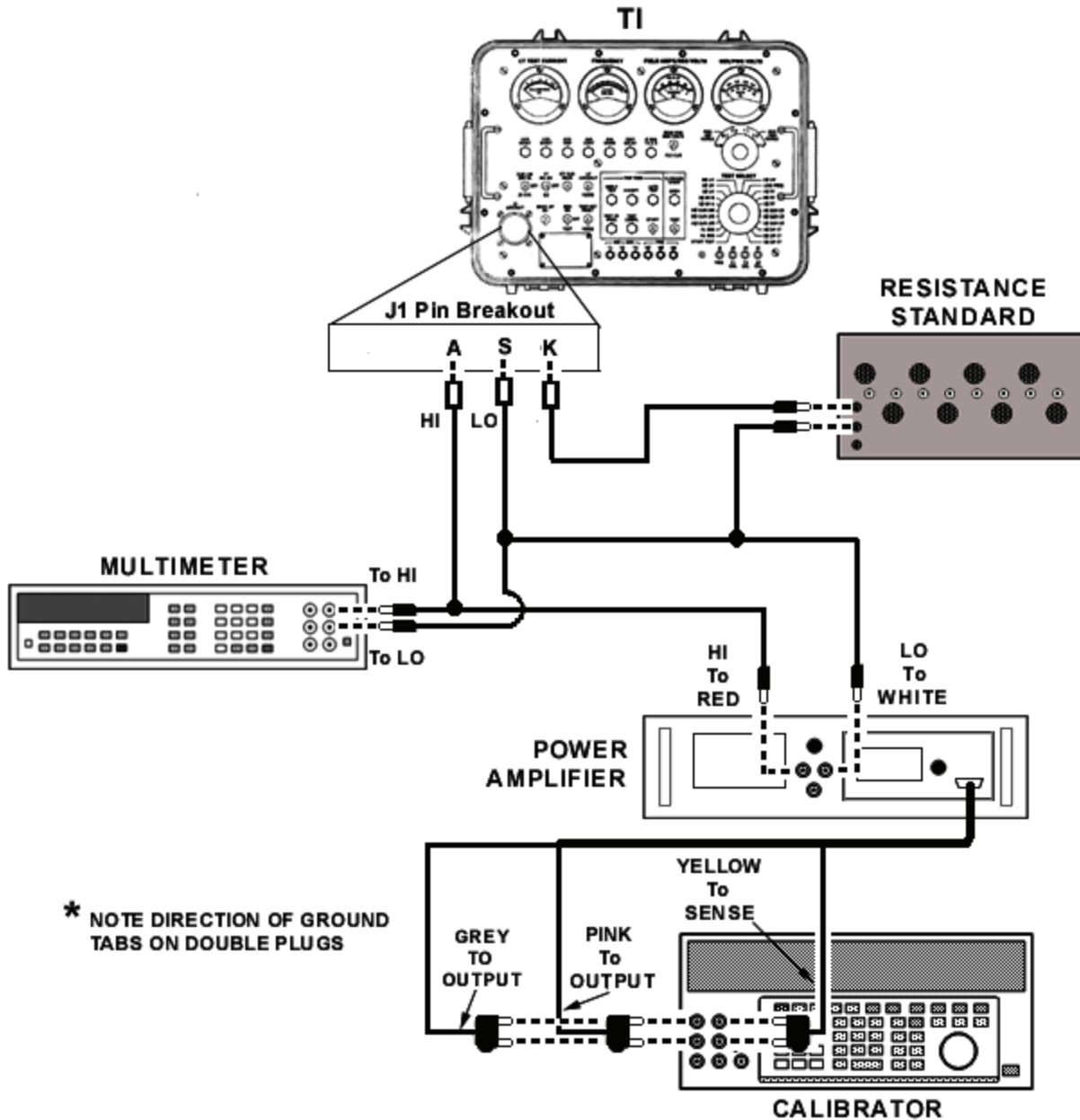

Figure 2. CT TEST CURRENT - equipment setup.

- (3) Adjust resistance standard to 3300 ohms.
- (4) Set calibrator to 1 V, 400 Hz and press **EX SENS**. Set calibrator to **OPR**.
- (5) Set power amplifier **OUTPUT VOLTAGE RANGE** switch to 200 V.

(6) Adjust **POWER AMPLIFIER GAIN** control to 115 V at 400 Hz as displayed on multimeter **ACV** and **FREQ** displays. **CT TEST CURRENT** meter will indicate between 0.9 and 1.1 mA dc.

(7) Adjust resistance standard to each setting listed in table 4. **CT TEST CURRENT** meter will indicate within the limits specified.

(8) Adjust **POWER AMPLIFIER GAIN** control fully ccw and set power amplifier **OUTPUT VOLTAGE RANGE** switch to 30 V.

(9) Press calibrator **RESET** key. Disconnect all equipment from TI.

Table 4. CT TEST CURRENT Meter

Resistance standard settings (Ω)	Test instrument CT TEST CURRENT meter indications (mA dc)	
	Min	Max
2100	1.4	1.6
1500	1.9	2.1
1100	2.4	2.6

b. Adjustments. No adjustments can be made.

11. FIELD AMPS/REG VOLTS Meter

a. Performance Check

(1) Connect calibrator **OUTPUT HI** directly to pin **g** and **LO** to pin **S** of **J1**.

(2) Set **READ REG BUS VOLTS-FLD CUR** switch to up position.

(3) Adjust calibrator output for a 30 V dc indication on **FIELD AMPS/REG VOLTS** meter. Calibrator will indicate between 28 and 32 V dc.

(4) Set calibrator to **STBY** and disconnect from TI.

(5) Connect calibrator amplifier **CURRENT OUTPUT HI** to pin **J** and **CURRENT OUTPUT LO** to pin **f** of **J1**.

(6) Set **READ REG BUS VOLTS-FLD CUR** switch to down position.

(7) Enter 1 A dc in calibrator display and press calibrator **BOOST** key.

(8) Adjust calibrator output for a 1 A dc indication on **FIELD AMP/REG VOLTS** meter. Calibrator will indicate between 0.8 and 1.2 A dc.

(9) Repeat technique of (8) above at **FIELD AMP/REG VOLTS** meter indications listed in table 5. Calibrator will indicate within limits specified.

(10) Press calibrator **RESET** and disconnect from TI.

Table 5. Field Amps Meter

Test instrument FIELD AMPS meter indications (A dc)	Calibrator Indications (A dc)	
	Min	Max
3	2.8	3.2
5	4.8	5.2

b. Adjustments. No adjustments can be made.

12. Timer Time Delay

a. Performance Check

(1) Connect dc power supply (+) to TI **J1** pin **J** and (-) to pin **S**. Set dc power supply **ON** and adjust for 28 V dc output.

NOTE

Use multimeter to set voltage and then disconnect multimeter from dc power supply. Set dc power supply to **OFF** instead of adjusting output to minimum when directed. This eliminates the need to readjust to proper voltages when turned on again in later checks.

CAUTION

Be aware that high voltage pulses are measured in the following checks. Ensure that proper frequency counter settings are utilized.

(2) Connect frequency counter **A** input to **J2 TRIG** and **B** input to **J4 T2 CAL**.

(3) Position frequency counter controls to preset settings except as listed in (a) through (i) below for time interval measurement:

- (a) Function to **TIME A - B**.
- (b) Press **MEASUREMENT TIME** and set to minimum (80 nsec).
- (c) Press **MEASUREMENT SINGLE** (**SINGLE** appears in display).
- (d) Set **INPUT A** and **INPUT B 50Ω/1MΩ** to **1MΩ**.
- (e) Press **TRIGGER LEVEL AUTO** key to deactivate auto trigger (**AUTO** removed from display).
- (f) Set **INPUT A** and **INPUT B 1X/10X** to **10X**.
- (g) Set **INPUT A** and **INPUT B TRIGGER LEVEL SET A** and **SET B** levels to 8.00 V.

NOTE

At the time of dynamic evaluation, this manually set trigger level was utilized to achieve correct readings from TI. These manually set levels may have to be varied to obtain an in-tolerance condition on pulse readings.

- (h) Set **INPUT A** and **INPUT B AC/DC** to **DC**.

- (i) Press **MEASUREMENT RESTART**.
- (4) Position controls as listed in (a) through (c) below:
 - (a) **TRIP TIME START** switch to off (down).
 - (b) **TEST SELECT** switch to **3Ø OVB**.
 - (c) Press frequency counter **RESTART**.

NOTE

Always press frequency counter **RESTART** button as many times as necessary to clear display before placing **TRIP TIME START** switch to on (up).

- (d) **TRIP TIME START** switch to on (up).
- (5) If frequency counter does not indicate between 100 and 140 ms, perform **b (1)** below.
- (6) Disconnect hookup from **J4 T2 CAL** and connect to **J3 T1 CAL**.
- (7) Position controls as listed in (a) through (d) below:
 - (a) **TRIP TIME START** switch to off (down).
 - (b) **TEST SELECT** to **AØ UV**.
 - (c) Press frequency counter **RESTART**.
 - (d) **TRIP TIME START** switch to on (up).
- (8) If frequency counter does not indicate between 3.0 and 4.0 s, perform **b (2)** below.
- (9) Disconnect hookup from **J3 T1 CAL** and connect to **J4 T2 CAL**.
- (10) Set **TRIP TIME START** switch to off (down), press frequency counter **RESTART**, then set **TRIP TIME START** switch to on (up). If frequency counter does not indicate between 4.5 and 5.5 s, perform **b (3)** below.
- (11) Disconnect hookup from **J4 T2 CAL** and connect to **J3 T1 CAL**.
- (12) Position controls as listed in (a) through (d) below:
 - (a) **TRIP TIME START** switch to off (down).
 - (b) **TEST SELECT** switch to **UND FREQ**.
 - (c) Press frequency counter **RESTART**.
 - (d) **TRIP TIME START** switch to on (up).
- (13) If frequency counter does not indicate between 900 and 1100 ms, perform **b (4)** below.
- (14) Disconnect hookup from **J3 T1 CAL** and connect to **J4 T2 CAL**.
- (15) Set **TRIP TIME START** switch to off (down), press frequency counter **RESTART**, then set **TRIP TIME START** switch to on (up). If frequency counter does not indicate between 2.5 and 3.5 s, perform **b (5)** below.

b. Adjustments

- (1) Adjust R1 (fig. 3) for a frequency counter indication of 120 ms (R).
- (2) Adjust R5 (fig. 3) for a frequency counter indication of 3.5 s (R).
- (3) Adjust R3 (fig. 3) for a frequency counter indication of 5.0 s (R).

- (4) Adjust R119 (fig. 3) for a frequency counter indication of 1000 ms (R).
- (5) Adjust R7 (fig. 3) for a frequency counter indication of 3.0 s (R).

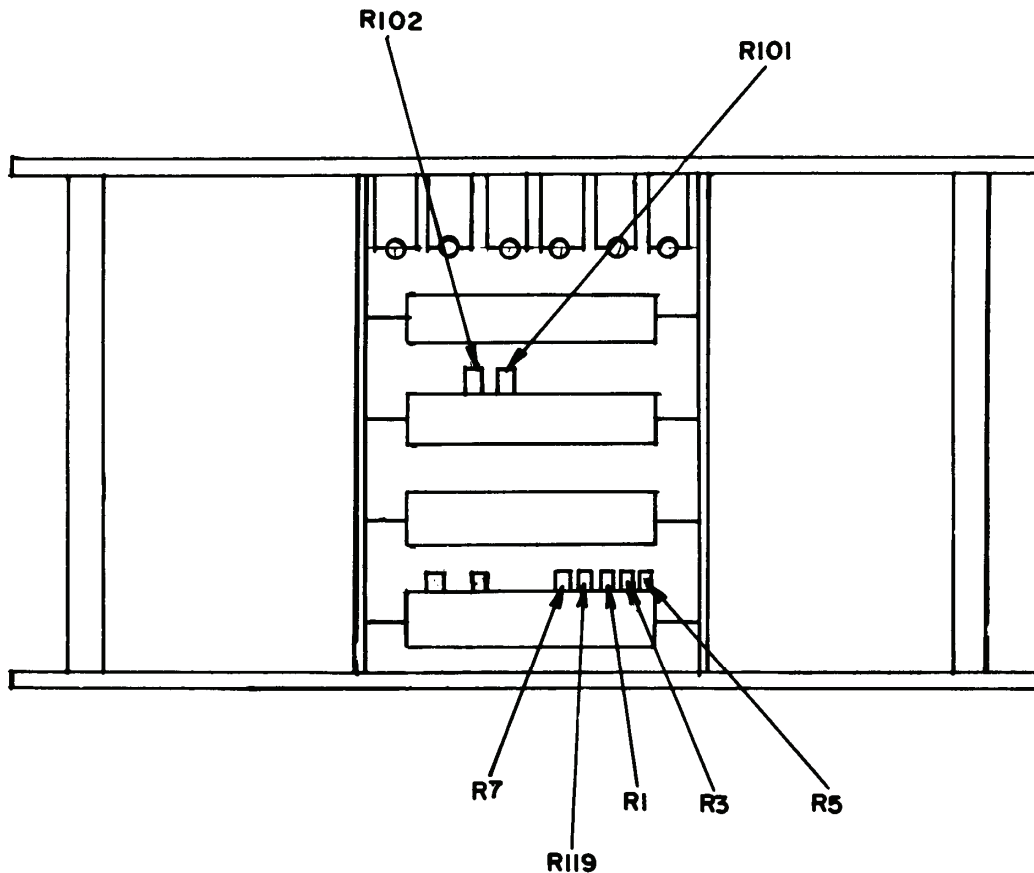

Figure 3. Test instrument - front view.

13. Underfrequency Circuit

a. Performance Check

- (1) Set dc power supply to **OFF** and disconnect frequency counter from equipment setup.
- (2) Press multimeter **ACV** key and connect to **J5 UFCAL**.
- (3) Set dc power supply to **ON**.
- (4) Set **TRIP TIME START** switch to off (down). Multimeter will indicate between 10 and 15 V ac.
- (5) Press multimeter **FREQ** key. If multimeter does not indicate between 1145 and 1165 Hz, perform **b (1)** below.
- (6) Set **TRIP TIME-START** switch to on (up). If multimeter does not indicate between 1085 and 1105 Hz, perform **b (2)** below.
- (7) Press multimeter **ACV** key. Multimeter will indicate between 10 and 15 V ac.

b. Adjustments

- (1) Adjust R101 (fig. 3) for 1155 Hz indication on multimeter (R).
- (2) Adjust R102 (fig. 3) for 1095 Hz indication on multimeter (R).

14. Final Procedure

- a. Deenergize and disconnect all equipment.
- b. Annotate and affix DA label/form in accordance with TB 750-25.

By Order of the Secretary of the Army:

Official:



JOYCE E. MORROW
*Administrative Assistant to the
Secretary of the Army*

0806003

GEORGE W. CASEY, JR.
*General, United States Army
Chief of Staff*

Distribution:

To be distributed in accordance with the initial distribution number (IDN) 342046, requirements for calibration procedure TB 9-4920-359-24.

Instructions for Submitting an Electronic 2028

The following format must be used if submitting an electronic 2028. The subject line must be exactly the same and all fields must be included; however, only the following fields are mandatory: 1, 3, 4, 5, 6, 7, 8, 9, 10, 13, 15, 16, 17, and 27.

From: "Whomever" whomever@redstone.army.mil

To: <2028@redstone.army.mil

Subject: DA Form 2028

1. **From:** Joe Smith
2. **Unit:** home
3. **Address:** 4300 Park
4. **City:** Hometown
5. **St:** MO
6. **Zip:** 77777
7. **Date Sent:** 19-OCT-93
8. **Pub no:** 55-2840-229-23
9. **Pub Title:** TM
10. **Publication Date:** 04-JUL-85
11. **Change Number:** 7
12. **Submitter Rank:** MSG
13. **Submitter FName:** Joe
14. **Submitter MName:** T
15. **Submitter LName:** Smith
16. **Submitter Phone:** 123-123-1234
17. **Problem:** 1
18. **Page:** 2
19. **Paragraph:** 3
20. **Line:** 4
21. **NSN:** 5
22. **Reference:** 6
23. **Figure:** 7
24. **Table:** 8
25. **Item:** 9
26. **Total:** 123
27. **Text**

This is the text for the problem below line 27.

